

Registration No : .....

SET 3

ALL KERALA COMMON MODEL EXAMINATION  
SCIENCE (086)

CLASS X (2023 - 24)

Time: 3 Hours

MAX. MARKS: 80

General Instructions:

1. This question paper consists of 39 questions in 5 sections.
2. All questions are compulsory. However, an internal choice is provided in some questions. A student is expected to attempt only one of these questions.
3. Section A consists of 20 objective - type questions carrying 1 mark each.
4. Section B consists of 6 Very Short questions carrying 02 marks each. Answers to these questions should be in the range of 30 to 50 words.
5. Section C consists of 7 Short Answer type questions carrying 03 marks each. Answers to these questions should be in the range of 50 to 80 words.
6. Section D consists of 3 Long Answer type questions carrying 05 marks each. Answers to these questions should be in the range of 80 to 120 words.
7. Section E consists of 3 source - based/case - based units of assessment of 04 marks each with sub - parts.

**Section A**

- 1 A student took Cu, Al, Fe and Zn strips separately in four test tubes labelled I, II, III and IV. He added 10 mL of freshly prepared ferrous sulphate solution to each test tube as shown below: [1]

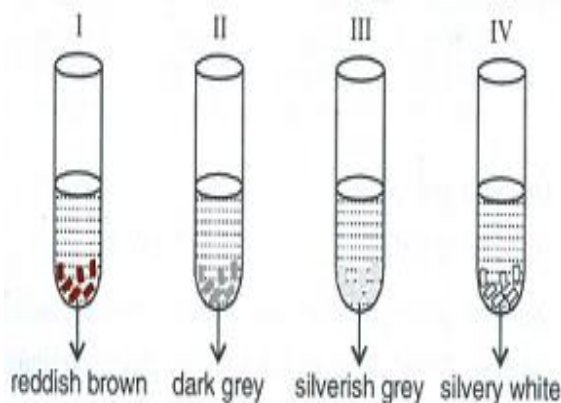

Black residue would be obtained in test tubes

- a) III and IV
- b) I, II and IV
- c) II and III
- d) II and IV

2 The crystals of ferrous sulphate on heating gives: [1]

- a)  $\text{FeO} + \text{SO}_3 + \text{H}_2\text{SO}_4 + \text{H}_2\text{O}$
- b)  $\text{Fe}_2\text{O}_3 + \text{SO}_2 + \text{SO}_3 + 7\text{H}_2\text{O}$
- c)  $\text{Fe}_2\text{O}_3 + \text{H}_2\text{SO}_4 + \text{H}_2\text{O}$
- d)  $\text{FeO} + \text{H}_2\text{O} + \text{SO}_2$

3 What happens when structure D contracts and flattens during the breathing process? [1]

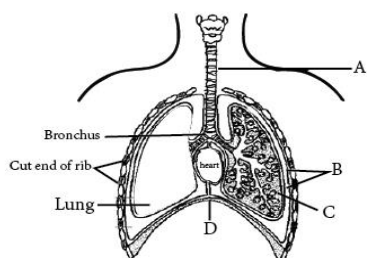

- a) (iv) Air is forced out of the lungs.
- b) (iii) The volume of thoracic cavity increases.
- c) (i) The air pressure inside lungs increases.
- d) (ii) The rib cage moves downwards and inwards.

4  $\text{C}_{60}$  and  $\text{C}_{70}$  are important members of which type of allotrope of carbon? [1]

- a) Fullerenes
- b) Diamond
- c) Graphite
- d) Coal

- 5 A metal is heated with dil  $\text{H}_2\text{SO}_4$ . The gas evolved is collected by the method shown in the figure. Answer the following questions based on it: [1]

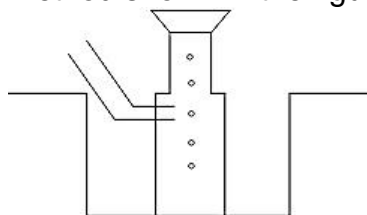

- The gas \_\_\_\_\_ than air and it is \_\_\_\_\_ in water.
- a) heavier, insoluble
  - b) lighter, insoluble
  - c) heavier, soluble
  - d) lighter, soluble
- 6 Which oxide will turn blue litmus solution to red? [1]
- A.  $\text{SO}_2$
  - B.  $\text{MgO}$
  - C.  $\text{Na}_2\text{O}$
  - D.  $\text{NO}_2$
- a) A and D
  - b) All of these
  - c) A and C
  - d) B and C
- 7 A molecule of ammonia ( $\text{NH}_3$ ) has [1]
- a) only triple bonds
  - b) two double bonds and one single bond
  - c) only single bonds
  - d) only double bonds
- 8 A leaf is boiled in alcohol before using iodine for starch test in order to: [1]
- a) Dissolve starch
  - b) Make it react with the iodine
  - c) Soften the leaf
  - d) Dissolve chlorophyll

- 9 The bleaching action of bleaching powder( $\text{CaOCl}_2$ ) is due to [1]
- a) Ca present
  - b) All of these
  - c) Oxygen present
  - d)  $\text{Cl}_2$  present
- 10 Nastic movements are non directional responses to stimuli. These movements are independent of the direction of stimuli. On the other hand growth movements which occur in direction of stimuli are called tropic movements. Which of the following is nastic movement? [1]
- a) movement of root of a plant towards a source of water.
  - b) closing of leaves of sensitive plants on being touched with an object.
  - c) climbing of a plant on an object using tendril.
  - d) bending of shoot of a plant in response to light.
- 11 In a plant, smooth seeds(S) are dominant over wrinkled seeds(s) and green seeds (G) are dominant over yellow seeds (g). A plant with smooth and green seed (homozygous) is crossed with a plant having wrinkled and yellow seeds. The  $F_1$  offspring are self crossed to produce  $F_2$  generation. If a total of 160 offspring are produced, how many plants are expected to be having wrinkled and green seeds in  $F_2$  generation, according to a typical Mendelian cross? [1]
- a) 30
  - b) 90
  - c) 10
  - d) 20
- 12 A plant gets rid of excess water through transpiration. Which method is used by plants to get rid of solid waste products? [1]
- a) expansion of roots into soil
  - b) shedding of yellow leaves
  - c) shortening of stem
  - d) dropping down of fruits
- 13 The fuse wire should have [1]
- a) High resistance, High melting point
  - b) High resistance, Low melting point

- c) Low resistance, Low melting point  
d) Low resistance, High melting point
- 14 What current will be taken by a 920 W appliance if the supply voltage is 230 V? [1]  
a) 4 A  
b) 1 A  
c) None of these  
d) 9 A
- 15 If a grasshopper is eaten by a frog, then the energy transfer will be from : [1]  
a) Producer to decomposer  
b) Primary consumer to secondary consumer  
c) Producer to primary consumer  
d) Secondary consumer to tertiary consumer
- 16 In the following groups of materials, which group (s) contains only non-biodegradable items? [1]  
i. Wood, paper, leather  
ii. Polythene, detergent, PVC  
iii. Plastic, detergent, grass  
iv. Plastic, empty medicine strip, DDT  
a) (ii) and (iv)  
b) (iv)  
c) (i) and (iii)  
d) (iii)
- 17 **Assertion (A):** When calcium carbonate is heated, it decomposes to give calcium oxide and carbon dioxide. [1]  
**Reason (R):** The decomposition reaction takes place on application of heat, therefore, it is an endothermic reaction.  
a) Both A and R are true and R is the correct explanation of A.  
b) Both A and R are true but R is not the correct explanation of A.  
c) A is true but R is false.  
d) A is false but R is true.

18 **Assertion (A):** Binary fission occurs in a definite orientation in Leishmania. [1]

**Reason (R):** Leishmania has whip like structure at one end of the cell.

- a) Both A and R are true and R is the correct explanation of A.
- b) Both A and R are true but R is not the correct explanation of A.
- c) A is true but R is false.
- d) A is false but R is true.

19 **Assertion (A):** A fault occurred in the domestic lines, but all the equipment's are safe. [1]

**Reason (R):** Potential difference is only 220 V in our country in domestic lines.

- a) Both A and R are true and R is the correct explanation of A.
- b) Both A and R are true but R is not the correct explanation of A.
- c) A is true but R is false.
- d) A is false but R is true.

20 **Assertion (A):** Blood clotting prevents excess loss of blood. [1]

**Reason (R):** Blood clotting is due to blood plasma and white blood cells in blood.

- a) Both A and R are true and R is the correct explanation of A.
- b) Both A and R are true but R is not the correct explanation of A.
- c) A is true but R is false.
- d) A is false but R is true.

### Section B

21 Ethene is formed when ethanol is heated at 443 K with excess of concentrated sulphuric acid. What is the role of sulphuric acid in this reaction? Write the balanced chemical equation of this reaction. [2]

- 22 Study the diagram and answer the following questions. [2]

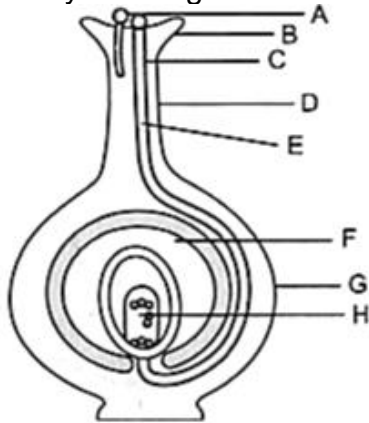

- i. What does the figure indicate?
  - ii. Mention the role of parts B, E?
- 23 (i) What is translocation? [2]
- (ii) Where do substances in plants reach as a result of translocation?

**OR**

How does transpiration help in the process of water transport in plants?

- 24 A convex lens can form a (i) real, inverted and magnified image as well as (ii) virtual, erect and magnified image of an object. If the focal length of the lens is 10 cm, what should be the range of the object distance in both cases? Draw ray diagram for any one of the above two cases to justify your answer. [2]
- 25 i. From the following group of organisms create a food chain which is the most advantageous for human beings in terms of energy. [2]
- Hawk, rat, cereal plant, goat, snake, human being
- ii. DDT was sprayed in a lake to regulate breeding of mosquitoes. How would it affect the trophic levels in the following food chain associated with the lake?
- plankton - - - - > small fish - - - - > large fish - - - > hawk

- 26 A student needs spectacles of power - 0.5 D for the correction of his vision. [2]
- i. Name the defect in vision the student is suffering from.
  - ii. Find the nature and focal length of the corrective lens.

**OR**

Draw ray diagram showing

- i. myopic eye.

- ii. What is the corrective lens used for myopia?

### Section C

- 27 You are given a hammer, a battery, a bulb, wires and switch. (a) How would you use them to distinguish between samples of metals and non metals? (b) Assess the usefulness of these tests to distinguish between metals and non - metals. [3]
- 28 Metal X is found in nature as its sulphide XS. It is used in the galvanisation of iron articles. Identify the metal X. How will you convert this sulphide ore into metal? Explain with suitable equations. [3]

### OR

- i. How do you classify elements into metals and non - metals on the basis of their electronic configuration? Choose metal and non - metal out of the following (any four) :  ${}_{11}^{23}A$ ,  ${}_{9}^{19}B$ ,  ${}_{12}^{24}C$ ,  ${}_{15}^{31}D$ ,  ${}_{17}^{35}E$
- ii. What type of bond will be formed if
- a. 'A' combines with 'B'?
- b. 'D' combines with 'E'?
- 29 (i) Draw a diagram of the human female reproductive system and label the part : [3]  
(a) where fertilisation occurs.  
(b) where contraceptive like copper - T is placed.  
(ii) What will happen in case the egg released by the ovary is not fertilised?
- 30 (i) With the help of a suitable monohybrid cross explain the Law of Dominance proposed by Gregor Mendel. [3]  
(ii) If a child inherits X chromosome from the father, what will be his/her gender?
- 31 a. A pencil when dipped in water in a glass tumbler appears to be bent at the interface of air and water. Will the pencil be bent to the same extent, if instead of water we use liquids like, kerosene or turpentine? Support your answer with reasons. b. The refractive indices 1.0003, 1.31 1.5 respectively of Air, Ice and Benzine in which of these does the light travels fastest? [3]
- 32 For the circuit shown in the given diagram: [3]

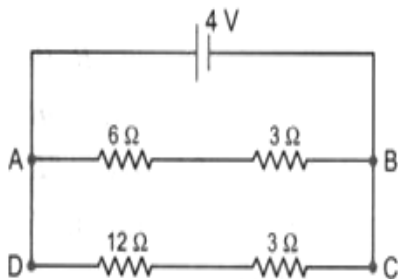



What is the value of

- i. current through  $6\Omega$  resistor?
  - ii. potential difference across  $12\Omega$  resistor?
- 33
- i. Explain the phenomenon involved in the following. [3]
  - ii. bluish colour of sky.
  - iii. formation of spectrum.
  - iv. raised position of a coin in water

### Section D

- 34 i. Write the names of the functional groups in [5]

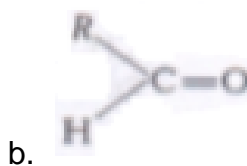
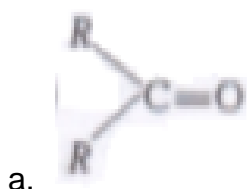

- ii. Describe a chemical test to distinguish between ethanol and ethanoic acid.
- iii. Write a chemical equation to represent what happens when hydrogen gas is passed through an unsaturated hydrocarbon in the presence of nickel as a catalyst?

**OR**

Identify the compounds A to E in the following reaction sequence.

- i.  $\text{CH}_3\text{CH}_2\text{OH} \xrightarrow{\text{KMnO}_4 + \text{KOH}} \text{A}$
- ii.  $\text{CH}_3\text{CH}_2\text{OH} + \text{A} \xrightarrow[\Delta]{\text{Conc. H}_2\text{SO}_4} \text{B}$
- iii.  $\text{B} + \text{NaOH} \rightarrow \text{C} + \text{CH}_3\text{CH}_2\text{OH}$
- iv.  $\text{A} + \text{NaHCO}_3 \rightarrow \text{C} + \text{D} + \text{H}_2\text{O}$
- v.  $\text{CH}_3\text{CH}_2\text{OH} + \text{E} \rightarrow \text{CH}_3\text{CH}_2\text{ONa} + \text{H}_2$

35 Observe the diagram given below and answer the questions:

[5]

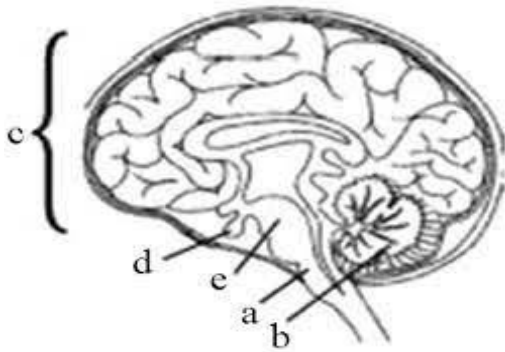

- (i) From the parts marked a to e, identify the part of the brain that has an endocrine function. Name the part. State its endocrine function.
- (ii) You are engaged in an activity like riding a bicycle. Identify and name the part of the brain (from the parts marked a to e) that makes you do this with precision.
- (iii) Name the part marked a. What is its role? (iv) How is the human brain protected?

**OR**

Observe the diagram given below and answer the questions that follow:

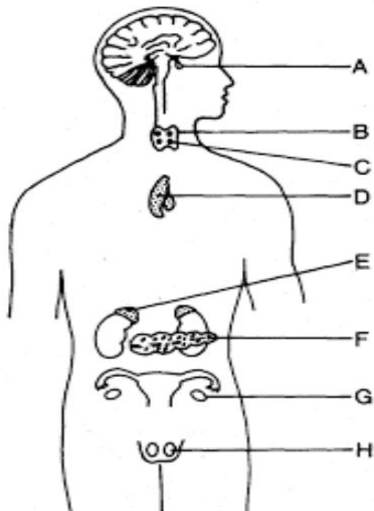

- (i) Name the hormones that are released in human females when they reach puberty.
- (ii) From the above diagram, identify and name a gland associated with brain. Name the hormone and the problem caused due to the deficiency of the hormone released by this gland during childhood ?
- (iii) Mr.X is advised by his family doctor to reduce intake of sugar. Name the disorder Mr. X is likely to be suffering from. Which endocrine gland and its secretion is malfunctioning in this case?
- (iv) How is the secretion of hormones regulated in the human body?

- 36 i. An object is placed in front of a convex lens of focal length  $f$ . If the distance of the object from the lens is  $2f$ , draw a ray diagram to show the formation of the image. State two characteristic of image formed. [5]
- ii. A student has focussed the image of a candle flame on a white screen using a convex lens. The situation is as given below: Length of the flame = 1.5 cm Focal length of the lens = 12 cm Distance of the flame from the lens = 18 cm If the flame is perpendicular to the principal axis of the lens, calculate the values of the following:
- Distance of the image from the lens
  - Length and nature of the image formed

**OR**

- i. Draw a ray diagram for showing the convergence of a parallel beam of light by a concave mirror and mark the positions of pole and the centre of curvature in it.
- ii. An object 4 cm in size is placed at 25 cm in front of a concave mirror of focal length 15 cm. At what distance from the mirror should a screen be placed in order to obtain a sharp image? Find the nature and size of the image.
- iii. List any two uses of a concave mirror.

### Section E

- 37 **Read the text carefully and answer the questions:** A scale for measuring hydronium ion in a solution is called the pH scale. The pH of a neutral solution is 7. A value of less than 7 on the pH scale represents an acidic solution. As the pH value, increases from 7 to 14 it represents  $\text{OH}^-$  ion concentration in solution i.e a basic solution. [4]

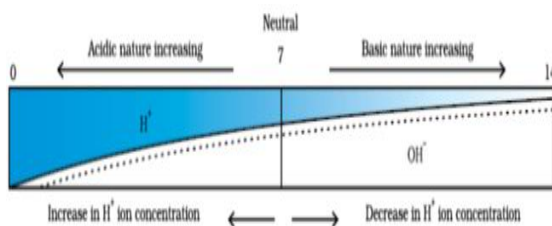

- What is the pH range of the Human Body?
- The strength of acid depends on which factor? (iii) If the pH of soil X is 7.5 while that of soil Y is 4.5, then which soil should be treated with powdered chalk to adjust its pH? Why?

**OR**

- ii. What is universal indicator? Mention the colour produced when pH paper is dipped in (a) HCl solution (b) Lime juice.

38 Read the text carefully and answer the questions:

[4]

The mode by which various organisms reproduce, depend on the body design of organisms. In asexual reproduction, a single individual parent produces offsprings without the involvement of gametes. This method is a common means of increasing the offsprings rapidly . Asexual reproduction occurs mostly in unicellular organisms and in some plants. There are many plants which reproduce asexually from parts like root, stem and leaves.

- i. Leaves of bryophyllum when falling on the ground can develop into new plants whereas a banana leaf is not able to do so. Why?
- ii. What happens when a sporangium in Rhizopus bursts on maturation?
- iii. How is budding in hydra different from budding in yeast ?

OR

- iii. How is fragmentation different from regeneration?

- 39 Read the text carefully and answer the questions: A student was asked to perform an experiment to study the force on a current carrying conductor in a magnetic field. He took a small aluminum rod AB, a strong horse shoe magnet, some connecting wires, a battery and a switch and connected them as shown. He observed that on passing current, the rod gets displaced. On reversing the direction of current, the direction of displacement also gets reversed. On the basis of your understanding of this phenomenon, answer the following questions:

[4]

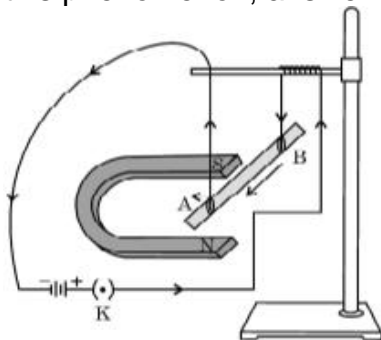

- i. Why does the rod get displaced on passing current through it?
- ii. State the rule that determines the direction of the force on the conductor AB.
- iii.
  - a. If the U shaped magnet is held vertically and the aluminum rod is suspended horizontally with its end B towards due north, then on passing current through the rod from B to A as shown, in which direction will the rod be displaced?

- b. Name any two devices that use current carrying conductors and magnetic field.

**OR**

- iii. Draw the pattern of magnetic field lines produced around a current carrying straight conductor held vertically on a horizontal cardboard. Indicate the direction of the field lines as well as the direction of current flowing through the conductor.

-----